

# Late Great Ladies - Lite Plot, Focus, Ground Plans

**Late Great Ladies of Blues and Jazz**  
**Focus plot - Specials** 3/15/95 C.C. Dunlop

## Legend

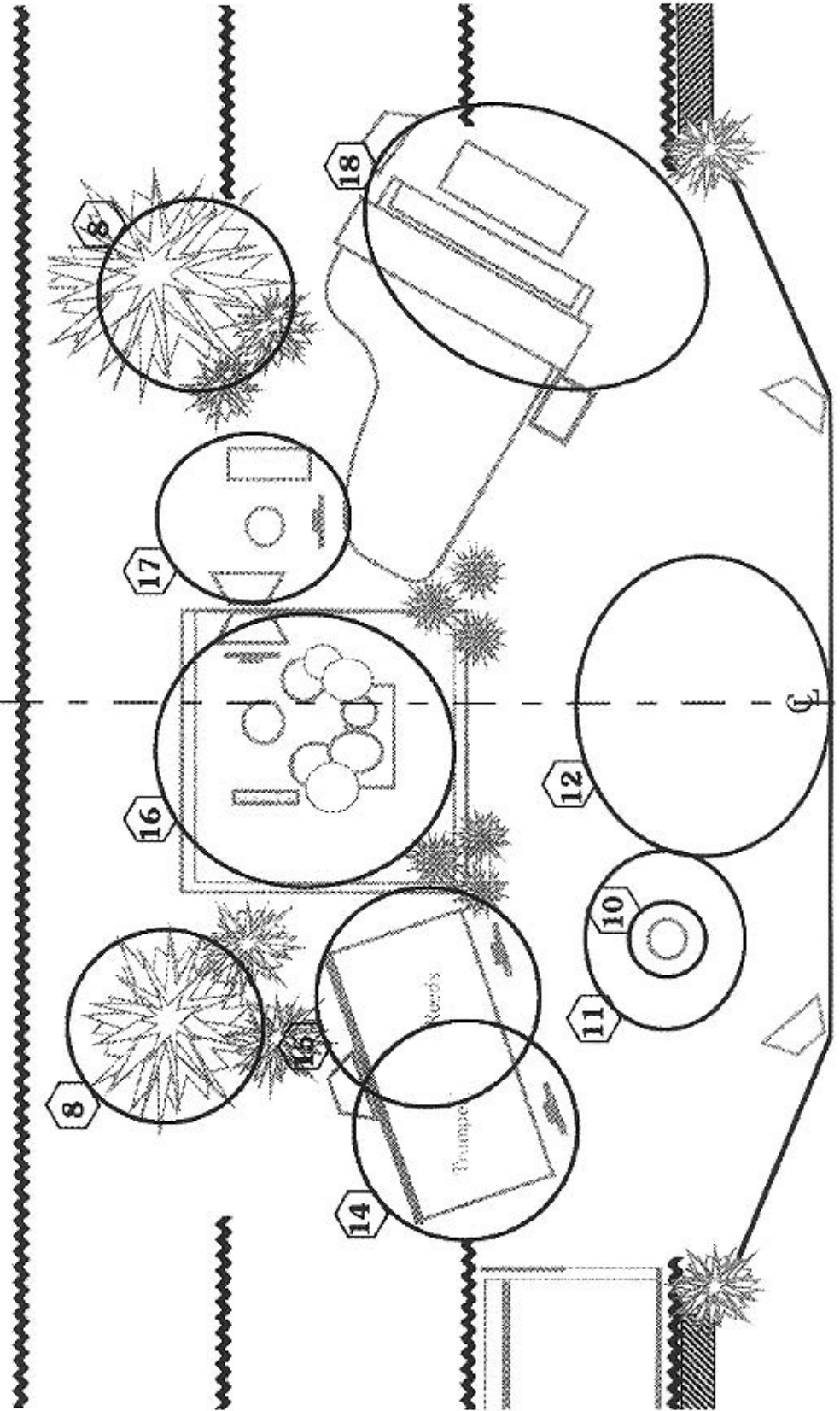

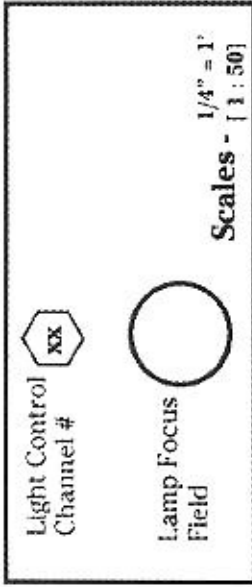
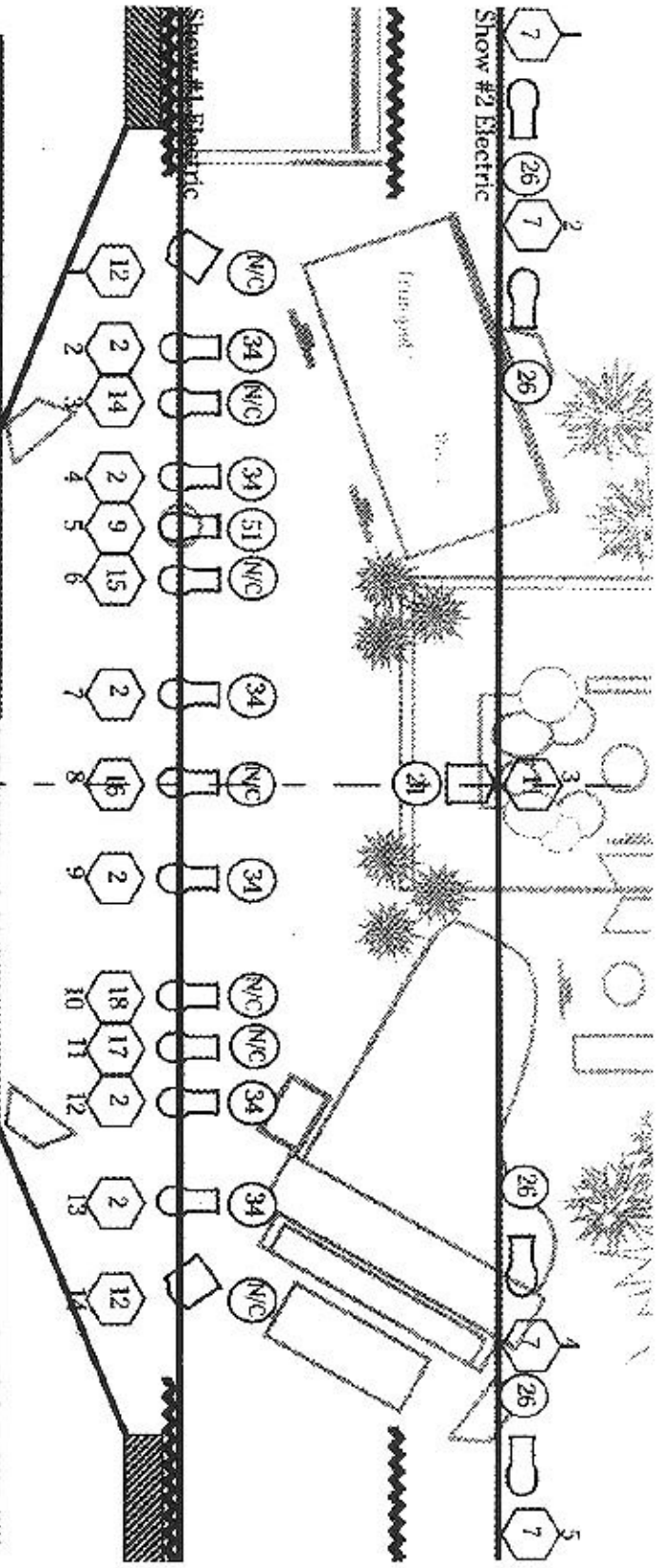

**Late Great Ladies of Blues and Jazz**  
**Light Plot - Front of House, 1st & 2nd Lx**  
 1/17/95 C.C. Dunlop

Control Channel #	UNIT # X	Color, Roscoflux #
6x9 [30°] Ellipsoidal		6x16 [15°] Ellipsoidal
		8" [2 Kw] Fresnel
Scales - 1/4" = 1' (1:50)		

Front of House Position

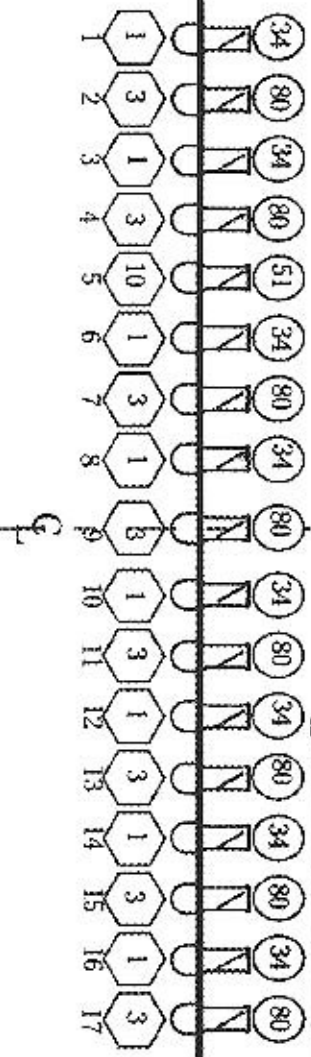

G F

**Late Great Ladies of Blues and Jazz**  
**Light Plot - Onstage** 1/17/95 C.C. Dunlop

**Legend**

Control Channel #	UNIT # X	Color, Roscoflux #	XX
6x9 [30°]	Ellipsoidal	8" Fresnel [2Kw.]	XX
Scales - 1/4" = 1'		6" Fresnel Floor Mount	

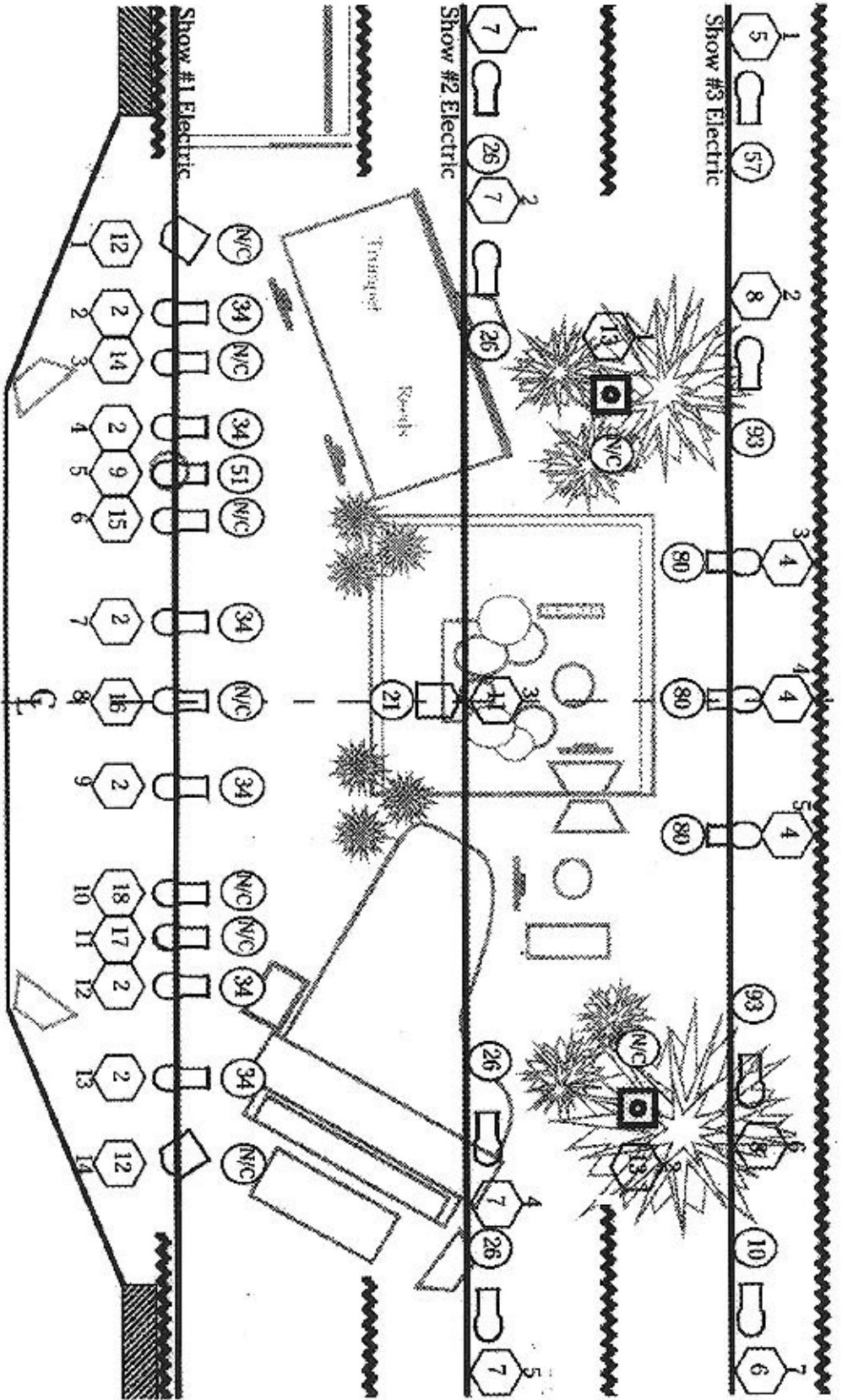

**Quick-Change Booth Interior Setup-Example**

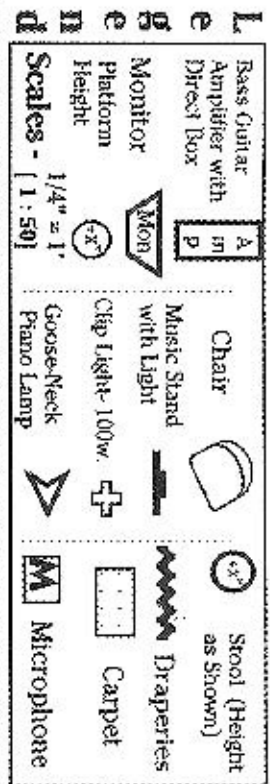
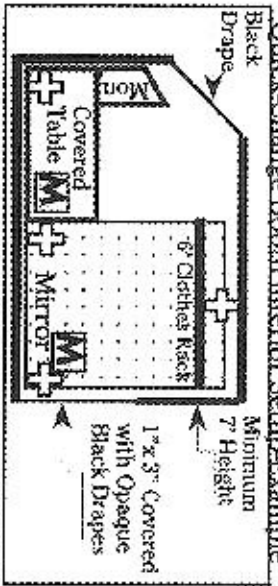

**Late Great Ladies of Blues and Jazz**  
3/15/95 C.C. Dunlop

